



Rear Compressor Drive Turbine Module

Alternate Sourcing – Repair
Tinker AFB - AFLCMC/LPSIB



MD:	F-15, F-16	
TMS:	F100-PW-220/229	
NOUN:	Rear Compressor Drive Turbine	
NSN:	2840013292336NZ	
P/N:	4067223	
Buy Price:	475722.00	
Date Last Procured:	2/22/2002	
Repair Cost:	252965.00	
AAC:	V	
Surplus Available:		
QPA/APPL Rate:	1	100
Replacement Rate:		



Out Year Requirements: BUY									
FY22:	0	FY23:	0	FY24:	0	FY25:	0	FY26:	0

Out Year Requirements: REPAIR									
FY22:	22	FY23:	24	FY24:	26	FY25:	27	FY26:	29

761:	Unavailable	762:	Available
EDL:	Unavailable	RDL:	Unavailable

COMMENTS



Rear Compressor Drive Turbine Module

Alternate Sourcing – Repair
Tinker AFB – AFLCMC/LPSIB



AMC/AMSC:		P
RMC/RMSC:	N/A	N/A
Material:		
Dimensions:	101"L X 61"W X 65"H	
Criticality Code:	Y	
Drawings Available:	Yes	
Drawing #:	4067223	
T.O. Available:	Yes	
T.O. #:	2J-F100.13-1-WA-1	
Budget Code:	8	
Drawing Cage Code:	77445	
Mesh File Available:		
Next Higher Asmbly:		

Health Chart Not Available

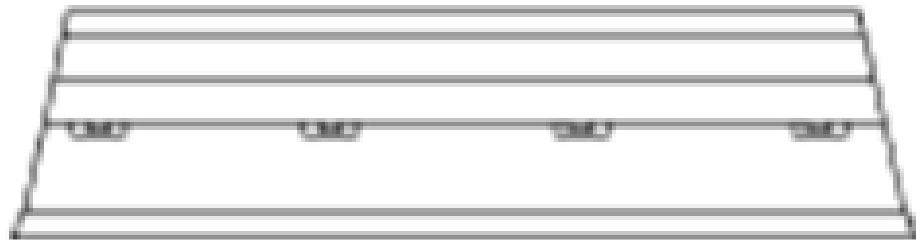

If you would like to participate in the Technical Discussion on
August 12, 2020, at 2:00-2:30 (CST)
 provide the following, NLT
Aug 5, 2020
429SCMS.SASPO.Workflow@us.af.mil
 -Company, -Address, -Name(s), -Email(s), -Phone, and,
 -Your questions for Engineering.



Fan Drive Turbine Module

Alternate Sourcing – Repair
Tinker AFB - AFLCMC/LPSIB



MD:	F-15, F-16	
TMS:	F100-PW-220/229	
NOUN:	Fan Drive Turbine	
NSN:	2840013394246NZ	
P/N:	4070217	
Buy Price:		
Date Last Procured:		
Repair Cost:		
AAC:		
Surplus Available:		
QPA/APPL Rate:	1	100
Replacement Rate:		

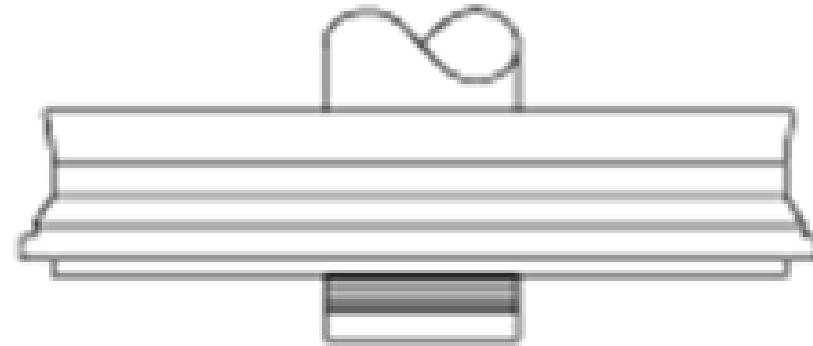

Out Year Requirements: BUY									
FY22:	0	FY23:	0	FY24:	0	FY25:	0	FY26:	0

Out Year Requirements: REPAIR									
FY22:	3	FY23:	4	FY24:	3	FY25:	3	FY26:	3

761:	Unavailable	762:	Available
EDL:	Unavailable	RDL:	Unavailable

COMMENTS

Item Not Stock Listed



Fan Drive Turbine Module

Alternate Sourcing – Repair

Tinker AFB – AFLCMC/LPSIB



AMC/AMSC:	4	P
RMC/RMSC:	N/A	N/A
Material:		
Dimensions:	92"L X 46"W X 51"H	
Criticality Code:	Y	
Drawings Available:	Yes	
Drawing #:	4070217	
T.O. Available:	Yes	
T.O. #:	2J-F100-13-1-WA-1	
Budget Code:		
Drawing Cage Code:	77445	
Mesh File Available:		
Next Higher Asmbly:		

Health Chart Not Available

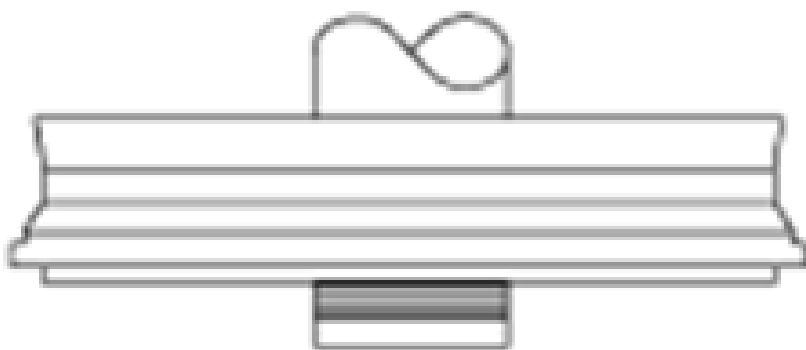

If you would like to participate in the Technical Discussion on

Aug 12, 2020, at 2:00-2:30 (CST)

provide the following, NLT

Aug 5, 2020

429SCMS.SASPO.Workflow@us.af.mil

- Company, -Address, -Name(s), -Email(s), -Phone, and,
- Your questions for Engineering.



Gear Box Module

Alternate Sourcing – Repair

Tinker AFB - AFLCMC/LPSIB



MD:	F-15, F-16	
TMS:	F100-PW-220/229	
NOUN:	Gearbox Module	
NSN:	2840013410067NZ	
P/N:	4067225-801	
Buy Price:	10,6029.00	
Date Last Procured:	6/8/2003	
Repair Cost:	102,254.10	
AAC:	V	
Surplus Available:		
QPA/APPL Rate:	1	100
Replacement Rate:		

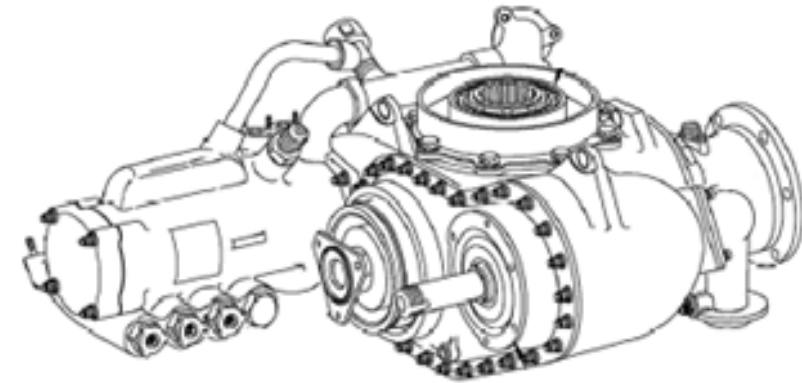

Out Year Requirements: BUY									
FY22:	0	FY23:	0	FY24:	0	FY25:	0	FY26:	0

Out Year Requirements: REPAIR									
FY22:	16	FY23:	16	FY24:	15	FY25:	14	FY26:	13

761:	Unavailable	762:	Available
EDL:	Unavailable	RDL:	Unavailable

COMMENTS



Gear Box Module

Alternate Sourcing – Repair

Tinker AFB – AFLCMC/LPSIB



AMC/AMSC:	0	0
RMC/RMSC:	N/A	N/A
Material:		
Dimensions:	35"L X 33"W X 25"H	
Criticality Code:	Y	
Drawings Available:	No	
Drawing #:	4067225	
T.O. Available:	Yes	
T.O. #:	2J-F100-13-1-WA-1	
Budget Code:	8	
Drawing Cage Code:	77445	
Mesh File Available:		
Next Higher Asmbly:		

Health Chart Not Available

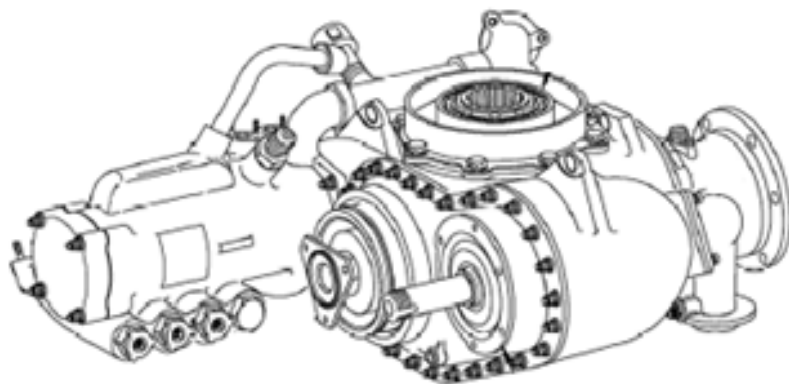

If you would like to participate in the Technical Discussion on
Aug 12, 2020, at 2:00-2:30 (CST)
provide the following, NLT
Aug 5, 2020
429SCMS.SASPO.Workflow@us.af.mil
-Company, -Address, -Name(s), -Email(s), -Phone, and,
-Your questions for Engineering.



Core Module

Alternate Sourcing – Repair

Tinker AFB - AFLCMC/LPSIB



MD:	F-15, F-16	
TMS:	F100-PW-220/229	
NOUN:	Core Module	
NSN:	2840013410175NZ	
P/N:	4067222-813	
Buy Price:	1,944,384.00	
Date Last Procured:	12/31/2004	
Repair Cost:		
AAC:	C	
Surplus Available:		
QPA/APPL Rate:	1	100
Replacement Rate:		

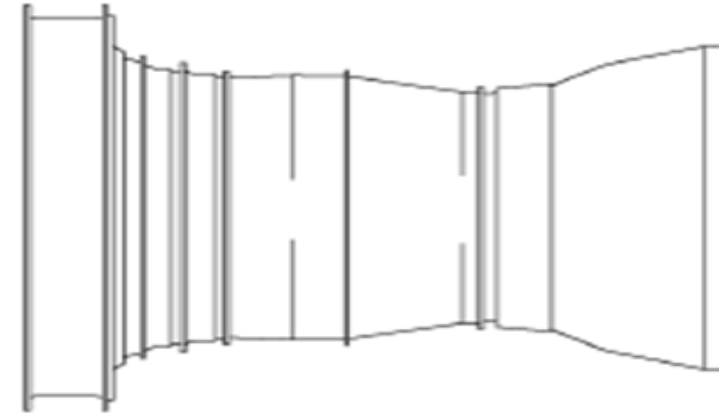

Out Year Requirements: BUY									
FY22:		FY23:		FY24:		FY25:		FY26:	

Out Year Requirements: REPAIR									
FY22:	15	FY23:	26	FY24:	28	FY25:	29	FY26:	31

761:	Unavailable	762:	Available
EDL:	Unavailable	RDL:	Unavailable

COMMENTS



Core Module

Alternate Sourcing – Repair

Tinker AFB – AFLCMC/LPSIB



AMC/AMSC:	3	V
RMC/RMSC:	N/A	N/A
Material:		
Dimensions:	101"L X 61"W X 65"H	
Criticality Code:	Y	
Drawings Available:	Yes	
Drawing #:	4067222	
T.O. Available:	Yes	
T.O. #:	2J-F100-13-WA-1	
Budget Code:	8	
Drawing Cage Code:	77445	
Mesh File Available:		
Next Higher Asmbly:		

Health Chart Not Available

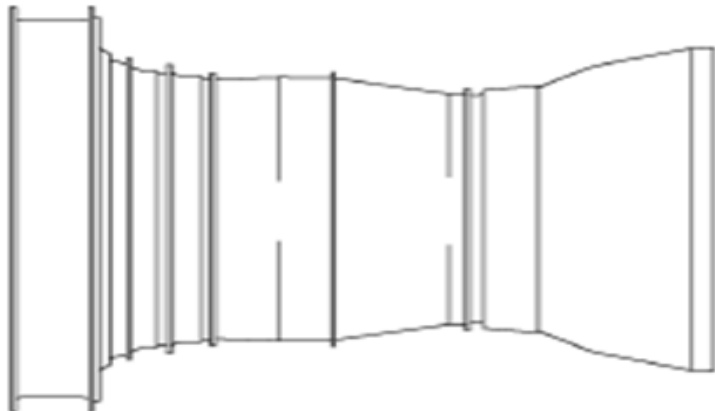

If you would like to participate in the Technical Discussion on

Aug 12, 2020, at 2:00-2:30 (CST)

provide the following, NLT

Aug 5, 2020

429SCMS.SASPO.Workflow@us.af.mil

- Company, -Address, -Name(s), -Email(s), -Phone, and,
- Your questions for Engineering.



Inlet Fan Module

Alternate Sourcing – Repair

Tinker AFB - AFLCMC/LPSIB



MD:	F-15, F-16	
TMS:	F100-PW-220/229	
NOUN:	Inlet Fan Module	
NSN:	2840013410177NZ	
P/N:	4081821-800	
Buy Price:	552,227.00	
Date Last Procured:	2/21/2002	
Repair Cost:	237012.72	
AAC:	V	
Surplus Available:		
QPA/APPL Rate:	1	100
Replacement Rate:		



Out Year Requirements: BUY									
FY22:	0	FY23:	0	FY24:	0	FY25:	0	FY26:	0

Out Year Requirements: REPAIR									
FY22:	22	FY23:	25	FY24:	28	FY25:	27	FY26:	28

761:	Unavailable	762:	Available
EDL:	Unavailable	RDL:	Unavailable

COMMENTS



Inlet Fan Module

Alternate Sourcing – Repair

Tinker AFB – AFLCMC/LPSIB



AMC/AMSC:	0	0
RMC/RMSC:	N/A	N/A
Material:		
Dimensions:	55"L X 25"W X 43"H	
Criticality Code:	Y	
Drawings Available:	Yes	
Drawing #:		
T.O. Available:	Yes	
T.O. #:	2J-F100-13-1-WA-1	
Budget Code:	8	
Drawing Cage Code:		
Mesh File Available:		
Next Higher Asmbly:		

Health Chart Not Available



If you would like to participate in the Technical Discussion on
Aug 12, 2020, at 2:00-2:30 (CST)
 provide the following, NLT
Aug 5, 2020
429SCMS.SASPO.Workflow@us.af.mil
 -Company, -Address, -Name(s), -Email(s), -Phone, and,
 -Your questions for Engineering.



Augmentor Module

Alternate Sourcing – Repair

Tinker AFB - AFLCMC/LPSIB



MD:	F-15, F-16	
TMS:	F100-PW-220/229	
NOUN:	Augmentor Module	
NSN:	2840013443336NZ	
P/N:	4068224-812	
Buy Price:	667,379.45	
Date Last Procured:	6/23/1995	
Repair Cost:	93,433.12	
AAC:	V	
Surplus Available:	0	
QPA/APPL Rate:	1	100
Replacement Rate:		

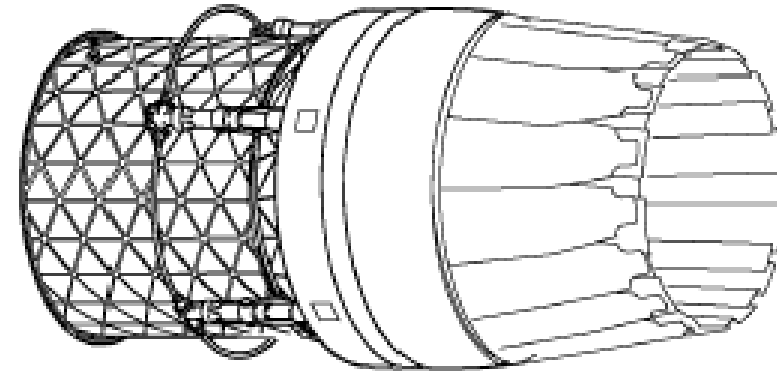

Out Year Requirements: BUY									
FY22:	0	FY23:	0	FY24:	0	FY25:	0	FY26:	0

Out Year Requirements: REPAIR									
FY22:	1	FY23:	1	FY24:	1	FY25:	1	FY26:	1

761:	Unavailable	762:	Available
EDL:	Unavailable	RDL:	Unavailable

COMMENTS



Augmentor Module

Alternate Sourcing – Repair

Tinker AFB – AFLCMC/LPSIB



AMC/AMSC:	3	C
RMC/RMSC:	N/A	N/A
Material:		
Dimensions:	113"L X 61"W X 69"H	
Criticality Code:	Y	
Drawings Available:	Yes	
Drawing #:	4068224-812	
T.O. Available:	Yes	
T.O. #:	2J-F100-13-1-WA-1	
Budget Code:	8	
Drawing Cage Code:	77445	
Mesh File Available:		
Next Higher Asmby:		

Health Chart Not Available

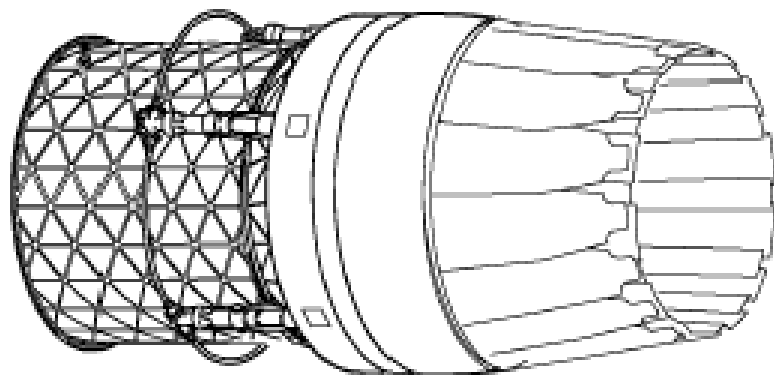

If you would like to participate in the Technical Discussion on

Aug 12, 2020, at 2:00-2:30 (CST)

provide the following, NLT

Aug 5, 2020

429SCMS.SASPO.Workflow@us.af.mil

- Company, -Address, -Name(s), -Email(s), -Phone, and,
- Your questions for Engineering.